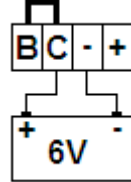
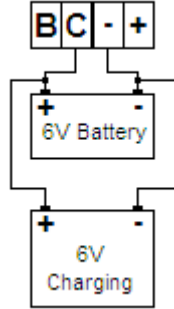
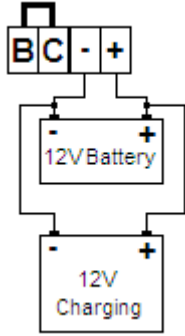

DT80 and DT81 (V6) Frequently Asked Questions

Mechanical		
Question	Answer	Notes
What mounting options are available?	Presently only via the cast end-plates. A DIN rail mount may become available as an accessory in the future.	Dependant on customer demand.
Vibration rating?	Not currently rated.	
Drop tested to what?	Drop test only in packaging for shipping purposes.	
Can I get 'blank' terminal label covers?	A clear label cover is shipped as a standard accessory (not with –AL models). Additional covers available as a spare part. The template for printing custom terminal assignments is on the resource CD.	
Battery/Power		
Question	Answer	Notes
How long will the internal battery last?	Continuous: 1 Hour. 10 Minute samples: 8 days. 1 Hour samples: 21 days. An external 6V lead acid battery of greater capacity can also be connected and charged by the <i>DT80/81</i> .	The <i>DT80/81</i> internal battery is not intended as the primary power source. It is intended to offer UPS functionality only.

DT80 and DT81 (V6) Frequently Asked Questions

<p>Can I add a larger external battery?</p>	<p>Yes, an external 6V lead acid battery can be connected and charged by the <i>DT80/81</i>.</p> <p>The suggested maximum rating of the external battery is 4A/hr unless an external charging system is used.</p>	<p>Larger capacity lead acid batteries take longer to charge. VBAT measurement will only be possible if the internal battery is removed and terminals B-C linked.</p> 
<p>How do I charge a large external 6V battery?</p>	<p>If the external 6V battery is larger than 4A/Hr then a separate charging circuit must be used. The internal battery must also be disconnected and the B-C link removed.</p> <p>In this configuration, no other power supply should be connected to the <i>DT80/81</i>.</p>	
<p>How do I use a 12V battery?</p>	<p>The <i>DT80/81</i> cannot charge a 12V battery so a separate charging circuit must be used. The internal battery may be left connected or can be disconnected if you wish.</p> <p>If the internal battery is connected, it will provide UPS functionality, to allow for short disconnection of 12V power. For example during maintenance. But this configuration will reduce the overall power system efficiency slightly.</p>	

DT80 and DT81 (V6) Frequently Asked Questions

<p>What happens when the battery is exhausted?</p>	<p>The <i>DT80/81</i> will shut down in a controlled fashion. No data will be lost as the binary format file used for data storage is inherently reliable; in addition, memory is also supported by the lithium backup battery. The logger will wake when external power is applied.</p>	
<p>How is the battery level displayed?</p>	<p>The standard display (not available with DT81) indicates current internal battery Voltage, current draw and 'state' (charging or discharging). Battery and power supply conditions can also be measured, logged and alarmed using as part of the DT80/81 program. The TEST command also returns battery and power supply operating details to a PC using <i>DeLogger™ 4</i>, <i>DeMobile™</i> or <i>DeTransfer™</i>.</p>	<p>Battery level in % is displayed but the calculation is only approximate.</p>
<p>What happens if the external supply fails?</p>	<p>The <i>DT80/81</i> will continue to run as programmed from the internal 6V battery until the external supply is restored.</p>	<p>The logger may go into low power mode depending on the actual application requirements and logger programming.</p>
<p>Can I power from external Battery?</p>	<p>Yes, 10-30 VDC via main power input terminals, or 6VDC Lead Acid via external battery terminals.</p>	<p>Note special considerations when using external 6V batteries.</p>
<p>Can I use a non standard external power supply (for example 24VDC)?</p>	<p>Yes, 10-30 VDC via main power input terminals or coaxial connector, approximately 12W minimum rating required.</p>	
<p>Can I connect directly to a solar panel for power?</p>	<p>Yes, however for best performance and battery life, we suggest the use of a solar conditioner or regulator.</p>	

DT80 and DT81 (V6) Frequently Asked Questions

Can the USB port power DT80/DT81?	No.	
Does the DT80/81 have a 5VDC supply for sensors like the DT500?	No, the DT80/81 has three methods of sensor excitation. <ol style="list-style-type: none"> 1. Switched excitation of 4.5V, 200uA or 2.5mA. 2. Switched excitation from an external supply. 3. Excitation using the Latching Relay. The 6V battery and main power supply may be used for sensor supply if care is taken in regard to ground loops and common mode.	Switched excitation is only available to that particular channel while it is being measured. Methods 2 and 3 require an external power supply be connected to the appropriate terminals.
How can I control power to a modem?	The DT80/81 can control power to a modem or other external device using the Latching Relay, alternatively using the digital output functions to control an external relay.	Relay and Digital Output functions can be controlled by Alarms, keypad Functions, schedules or DO and IF commands.
Host Communications		
Question	Answer	Notes
USB 2.0 Compliant?	The DT80/81 USB Slave port Operates to the requirements of USB 1.1 and can be used with USB 2.0 but at USB 1.1 rates.	
Does the logger appear as a 'plug & play' device via USB?	Yes, when the logger is connected the appropriate driver will be installed. You may be prompted to insert the driver CD. The driver is supplied with the dataTaker Resource CD or will be automatically located on the web by WinXP.	Driver is the same as used with our USB-RS232 adapter, if this unit has already been installed, the DT80 will use the same driver automatically. Once installed the DT80/81 appears as a Virtual Comms Port.

DT80 and DT81 (V6) Frequently Asked Questions

Can a USB hub be used?	Yes.	
Can I connect to the logger remotely?	Yes via serial Modem or Ethernet.	Standard version of <i>DeLogger</i> 4 doesn't include dial up modem support.
Can I connect over the web?	<p>Yes, you can connect to the <i>DT80/81</i> over a web connection in a number of ways.</p> <p>(1) Full host access and control via a conventional host package such as <i>DeLogger</i> or <i>DeTransfer</i>.</p> <p>(2) FTP using a FTP client or Web browser allows access to data store files. Files can be moved to your PC then data viewed using <i>DeView</i> or <i>DeLogger4</i>.</p> <p>(3) Web Interface included from V6 allows current data and status to be viewed from either the included HTML web pages or user developed custom pages.</p> <p>(4) Modbus SCADA interface for access to current data and status.</p>	Can see FTP folders from IE and other browsers. Must be remote request from FTP Client. Supports anonymous login – read only.
What if I connect to USB and Serial ports simultaneously?	The USB and serial ports may be physically connected at the same time but the logger will talk to only one external host at a time on a first come first served basis.	USB comms is default on reset if both are connected. Communications will autoswitch to whichever port was used last.
Can the logger connect to my Ethernet network?	Yes, using the standard Ethernet port you can connect to a LAN or WAN.	

DT80 and DT81 (V6) Frequently Asked Questions

Can multiple users connect over Ethernet?	Yes, multi user has limited functionality. The same actual data is returned to all connections, but data viewed in <i>DeLogger</i> etc can be displayed differently. Built-in and Custom HTML web pages can be used to display current data and status relevant to a particular user type.	
Is the RS232 port Isolated?	The RS232 Host port is not isolated, but the Communications/Digital/Power section is isolated from the Analog system.	
USB Isolation?	As per RS232 Isolation above.	
Do I need to upgrade <i>DeLogger 4</i> for use with V6?	No, but not all new features will be available directly from the program builder, User channel type can be used to access these features.	SDI-12 channel types and Modbus commands are not yet supported by <i>DeLogger 4</i> .
Do I need to upgrade <i>DeLogger 4</i> for use with the DT81?	Yes. The <i>DT81</i> will be supplied with the updated version of <i>DeLogger</i> that supports it.	
Do I need to upgrade <i>DeTransfer</i>?	No, but some <i>DeTransfer</i> menu functions are not applicable to the DT80/81 at present..	Menu items; Prepare card for upgrade.
Do I need to upgrade <i>DeLoad for V6</i>?	No	V2.27 or later is required.
Do I need to upgrade <i>DeLoad for the DT81</i>?	Yes	Available by end of June 2006.

DT80 and DT81 (V6) Frequently Asked Questions

Do I need to upgrade <i>dataTaker ActiveX</i>?	Yes	Available by end of June 2006.
Do I need to upgrade the LabVIEW™ driver?	No, but some supplied VIs may require minor modification to suit user requirements.	
Does <i>DeMobile</i> work with the DT80/81?	Yes, the DT80/81 works with <i>DeMobile8</i> .	
Can I print direct from the logger?	Yes, but only to a serial printer that will accept standard ASCII text and control characters. These units are commonly known as Line Printers. Other suitable printers may include the small docket printers used for POS (Point Of Sale) transactions.	
Modbus		
Question	Answer	Notes
Does it support Modbus?	Yes, the DT80/81 (from V6) includes support for Modbus on Ethernet and all serial ports including the Serial Sensor port (DT80 only). The DT80/81 is a Modbus 'server' or 'slave' and will respond to requests from a Modbus 'client' or 'master'. If using the RS422/485 the Serial port address can be modified by the MODBUS_SERVER profile settings.	Note that once configured as a Modbus port, serial ports are not available other use. Refer to the user manual for detailed Modbus information.

DT80 and DT81 (V6) Frequently Asked Questions

Can I 'poll' data from another device?	No, the <i>DT80/81</i> is a Modbus 'server' or 'slave' and cannot issue requests to another slave device.	
Does it support Modbus Plus?	No.	
Can I read historical data via Modbus?	No, only current data available via Channel Variable (CVs) can be accessed. Large amounts of data can be classified by use of the Histogram functionality which is then available via CVs.	For small amounts of historical data use multiple CVs in a shift register arrangement.
Can I 'write' data or values to the <i>DT80/81</i>?	Yes, values can be written directly to <i>DT80/81</i> Channel Variables (CVs) for use within the data logger program or to be logged. Digital outputs can also be accessed directly by Modbus 'write' commands.	
Can I program the <i>DT80/81</i> via Modbus?	No, the data logger must be programmed seperately.	
Web Interface		
Question	Answer	Notes
What is a web interface?	The <i>DT80</i> 's inbuilt web interface provides a convenient way to access current data values and status information from any web browser (no additional software required).	Refer to the user manual for detailed Web Interface information.
Can I program my logger from a web browser?	Not at the current time.	

DT80 and DT81 (V6) Frequently Asked Questions

Can I view real-time data in a web browser?	The data available is not real-time, but is the current or most recent data from all scanned channels. The data updates at the same rate as the schedule, the displayed data in the web page updates at 30 second interval for the default views provided. Custom web pages can update at a faster rate.	Channels not available for view if channel options for ND (No Display) or W (Working) are set.
Can I view historical data in a web browser?	No, but you can navigate the data store files and download these for viewing on your local PC.	Requires <i>DeView™</i> or <i>DeLogger</i> to view and export data files.
Can I design my own HTML pages?	Yes, the <i>DT80/81</i> can serve customised web pages to suit specific applications.	Custom web pages are stored on the internal compact flash drive. This drive is shared with data storage.
Can I view charts and mimics from a web browser?	Not at the current time, channel data can however be arranged as required on custom pages.	
Display & Keypad (DT80 only)		
Question	Answer	Notes
How many channels can I view on the loggers display at the same time?	1 channel at a time, the actual channel or alarm shown is selected by pressing the up and down directional keys on the front panel.	
Can I view stored (historical) data on the loggers display?	No, only current data (the most recent value for each channel) and Alarm information can be viewed. In addition current Status information and System Warning message are also displayed.	

DT80 and DT81 (V6) Frequently Asked Questions

Can I control which data is available for display?	Yes, using ND channel options for data and Alarms. Status screens can be enabled or disabled for display by P19.	
Can I program the logger from the keypad?	No, but it is possible to utilise the programmable Functions to load and run named 'Jobs'.	Requires previous programming of Functions.
Can I start and stop a program or schedule from the keypad?	Yes, by using the programmable Functions.	Requires previous programming of Functions.
Can I control logging from the keypad?	Yes, by using the programmable Functions.	Requires previous programming of Functions.
Can I enter data from the keypad?	No, however direct commands can be programmed as Functions. Examples; FUNCTION1="Increase"{1CV=1CV+1} Increases the value of 1CV each time Function1 is selected and the 'OK (Edit)' key pressed. FUNCTION1="Zero"{1CV=0} Resets the value of 1CV each time Function1 is selected and the 'OK (Edit)' key pressed.	Requires previous programming of Functions. Future firmware will allow editing of CVs directly.
How many programmable functions are available?	10 different functions can be configured at any one time. It is possible to modify the function programming at any time via host PC or USB flash disk with oninsert.dxc file.	

DT80 and DT81 (V6) Frequently Asked Questions

<p>Can I remove the 2 standard Functions for copying data and removing the USB flash disk?</p>	<p>Yes, program functions 9 & 10 to be blank. Example; FUNCTION9= FUNCTION10=</p>	<p>In text program or in immediate schedule of <i>DeLogger</i> 4 within USER channel type.</p>
<p>Are Functions unique to a Job?</p>	<p>No, the Functions retain their programming unless specifically overwritten, or the logger is reset.</p>	
<p>What does the 'Edit' key do aside from OK functions?</p>	<p>Reserved for future use.</p>	
<p>Can you lock and disable the keypad?</p>	<p>Not directly, however programmable Functions can be disabled by appropriate programming.</p>	<p>Set functions to 'empty'</p>
<p>What does the Attn LED indicate?</p>	<p>The attention (attn) indicator is illuminated when the logger requires attention. It may be flashing or continuous depending on the reason for attention, some causes also display a short message on the display <i>DT80</i> only). Flashing; Unable to log data, Abnormal reset, Power failure or Internal failure. The attention indicator will blink until the user presses a key on the front panel (<i>DT80</i> only) or issues the CATTN command. Continuous; Controlled by user program (1WARN or SATTN). Unable to transfer data to USB flash disk.</p>	<p>Note that the <i>DT81</i> does not have a display or keypad, the Attn LED can only be turned off by program control (example: ALARM based on digital input) or the CATTN command via a host connection (<i>DeLogger</i>, <i>DeTransfer</i>, <i>DeLoad</i> etc).</p>

DT80 and DT81 (V6) Frequently Asked Questions

USB Flash Disk & Master Port.		
Question	Answer	Notes
What can I plug into the USB port on the front panel?	The USB Master port is only designed to support USB flash disks, often called USB 'memory sticks'.	Additional low power devices such as MP3 players and digital cameras may also be recognised as flash disks and could be used for transfer of data from or programs to the <i>DT80/81</i> .
USB flash disk devices – are there any type to be avoided?	Almost any USB flash disk should work, although performance may vary. Devices including a CD emulation function (autorun) should not be used.	Devices requiring high power such as micro drives are not supported.
Can I program the logger from the USB flash disk device?	Yes, either global or unit specific (using S/N for identification) oninsert.dxc files can be used to program a <i>DT80/81</i> without needing a PC to be present.	

DT80 and DT81 (V6) Frequently Asked Questions

<p>Can I prevent the logger from being reprogrammed by the USB flash disk device?</p>	<p>Yes, the logger programming can be locked by using the command LOCKJOB" JobName".</p>	
<p>Do I need to have a USB flash disk in the slot to log data?</p>	<p>No, the USB flash disk is intended primarily for transfer of data. If you want to log directly to the USB flash disk this is an option in the schedule options.</p>	<p>See section on 'USE OF MEMORY' for detailed information on memory allocation.</p>
<p>Can I log data direct to the USB flash disk?</p>	<p>Yes, but default is the internal data store. If you want to log directly to the USB flash disk this is an option in the schedule options.</p>	<p>See section on 'USE OF MEMORY' for detailed information on memory allocation. USB disk is slower than internal disk.</p>
<p>What happens when I remove the USB flash disk while logging to it?</p>	<p>The logger will continue operating, but it will not log data from schedules set to log to the USB flash disk.</p>	
<p>Is data transfer to the USB flash disk automatic?</p>	<p>No, however automation is possible by including the COPYDATA command in an oninsert.dxc file on the flash disk. Alternatively an Alarm in the logger program can detect the presence of the USB flash disk and run the COPYDATA command automatically. By default the user can access the COPYDATA command via a default keypad Function (Copy logged data).</p>	

DT80 and DT81 (V6) Frequently Asked Questions

<p>What happens if the USB flash disk is full when I try to transfer data?</p>	<p>The <i>DT8/810</i> will not be able to transfer data and will generate a 'Disk Full' error. The attention LED will be turned on and remain on until the USB flash disk is removed.</p>	
<p>Can I open the file directly from the flash disk?</p>	<p>Yes, using <i>DeView</i> or <i>DeLogger</i> to view or export data.</p>	<p>File is binary format. Alarms not currently accessible.</p>
<p style="text-align: center;">Internal Data Store</p>		
<p>Question</p>	<p>Answer</p>	<p>Notes</p>
<p>How long will the memory last?</p>	<p>The internal 64MB Compact Flash card provides storage for up to 5 million readings. By default each schedule is allocated a 1MB storage file which is adequate for 90,000 readings. The file size for any schedule can be set to suit the application. A larger internal card can be installed if required. How long the memory will last in time is dependant upon the number of channels set per schedule and the sample rate used for that schedule. Example; If 6 channels are logging every 10 seconds, it would take approximately 35 hours to fill a 1MB file. By increasing the allocated file size to 10MB, it would take approximately 15 days to fill the 10MB file.</p>	<p>See section on 'USE OF MEMORY' for detailed information on memory allocation.</p> <p>Note: Time and Date are included as readings in each schedule.</p> <p>Note: Each Alarm uses 256bytes and consequently reduces data storage accordingly.</p> <p>File size can be set in units;</p> <ol style="list-style-type: none"> 1. Time period. 2. Records. 3. Memory (bytes).

DT80 and DT81 (V6) Frequently Asked Questions

<p>What happens when the memory is full?</p>	<p>Each schedule can be set to either overwrite old data (default) or log only until the allocated file has been filled. If set to store to fill, the logger will continue to run as programmed, however that particular schedule will not store any further data. Other schedules that are set to overwrite, or that have not yet filled their allocated files will continue to store data.</p>	<p>See section on 'USE OF MEMORY' for additional information on memory modes.</p>
<p>Schedules</p>		
<p>Question</p>	<p>Answer</p>	<p>Notes</p>
<p>What is a schedule?</p>	<p>A schedule is a group of tasks that will be performed using a common rate or trigger. Each schedule has a binary data store file for Data and Alarms related to that schedule. Each schedule has unique trigger settings for rate, file size, logging etc. Each schedule can be started or halted separately. A total of 13 schedules are available, 11 are general purpose, 1 is for statistical data and one is a polled (only) schedule.</p>	<p>Refer to the Users Manual for detailed information on schedules.</p>

DT80 and DT81 (V6) Frequently Asked Questions

<p>How fast can I set the schedule trigger rate?</p>	<p>The <i>DT80/81</i> will accept schedule triggers down to 10mS (10T), although actual logging may not be achieved at that rate. The fastest speed that can be obtained in practice will depend on the tasks contained within that schedule and the effect of other tasks being performed by the logger, including writing to memory.</p> <p>For most practical purposes a setting of 100mS (100T) for analog channels would be considered maximum rate.</p> <p>It is possible to trigger continuously, which will run the schedule as fast as possible.</p> <p>Note that digital channels, system channels, channel variables (CVs) and Serial Sensor channels can be scanned at higher rates than analog inputs.</p>	
<p>Does the <i>DT80/81</i> have 'Burst Mode'?</p>	<p>No, the <i>DT80/81</i> is not designed for high speed logging.</p>	<p>Note: P62=1 leaves mux relays ON between scans which can be used to achieve maximum scanning rate possible on a single channel.</p>
<p>How can I capture events?</p>	<p>Schedules can be triggered by events such as change of state for a digital input, counter, channel variable or Serial Sensor activity. In addition the ARCHIVE command will allow pre and post event data to be captured.</p>	<p>See sections on USE OF MEMORY and PROGRAMMING AND COMMANDS for further for more details on the ARCHIVE command. Refer to the user manual for detailed command information.</p>

DT80 and DT81 (V6) Frequently Asked Questions

<p>Can I have different channels logging at different speeds?</p>	<p>Yes, use more than one schedule. Each schedule has unique trigger settings for rate. A total of 13 schedules are available, 11 are general purpose, 1 is for statistical data and one is a polled (only) schedule.</p>	
<p>Analog Inputs</p>		
<p>Question</p>	<p>Answer</p>	<p>Notes</p>
<p>What does ‘Universal’ or Versatile’ mean in regard to the <i>dataTaker</i> analog inputs?</p>	<p>A basic concept of the <i>dataTaker</i> data logger is that analog inputs can be used with more than one type of sensor, without needing additional input modules.</p> <p>The <i>dataTaker</i> analog channel is a group of 4 terminals that can be used in many combinations. On the <i>DT80</i> we have 5 (<i>DT81</i>=1), 4 wire (4 terminal) channels that allow sensors and signals based on voltage, current, resistance and frequency to be measured. These are the fundamental signals output by most sensors. It is not necessary to use all four terminals on each channel.</p> <p>Each of these channels can be connected to between 1 and 3 sensors or signals, depending on the requirements of that sensor or signal type.</p>	<p>Refer to the user manual for detailed connection information.</p>

DT80 and DT81 (V6) Frequently Asked Questions

How many analog inputs can I use on the DT80/81?

Example: 1 only RTD input per 4 wire dataTaker universal channel.

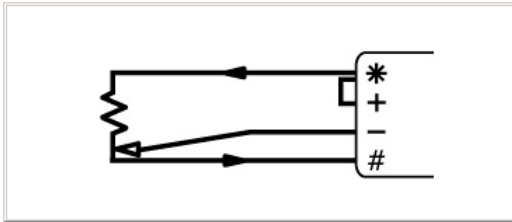

DT80: From 5 to 15 depending on the input or sensor type.

DT81: From 1 to 3 depending on the input or sensor type.

The universal analog inputs used on the DT80/81 allow from 1 to 3 inputs per 4 wire 'channel'.

Example: Up to 3 Voltage based inputs per 4 wire dataTaker universal channel.

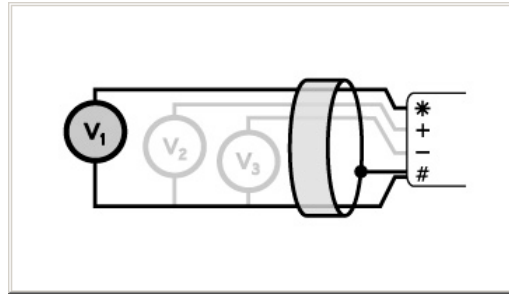

Refer to the user manual for detailed connection information.

Example: 1 full bridge strain gauge input per 4 wire dataTaker universal channel.

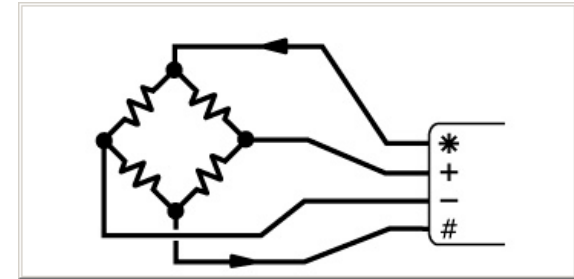

DT80 and DT81 (V6) Frequently Asked Questions

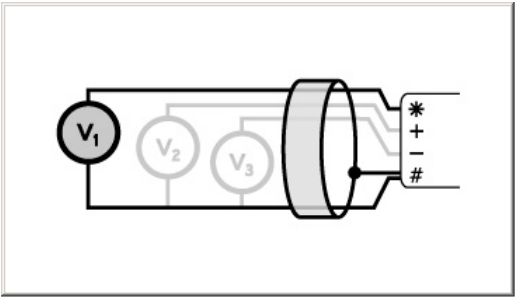
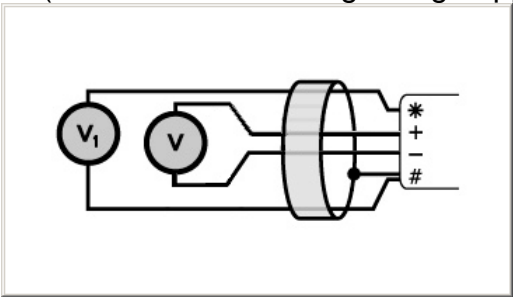
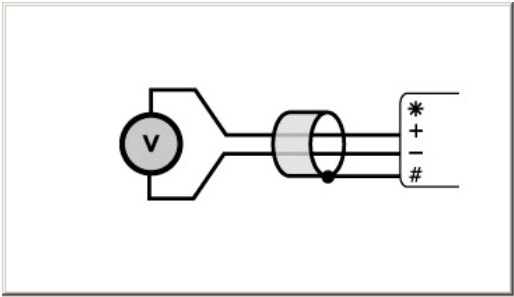
<p>How many voltage inputs can I use?</p> <p><i>Example: Up to 3 inputs per 4 wire dataTaker universal channel.</i></p> 	<p><i>DT80:</i> Up to 15 voltage based inputs can be used. These will be arranged in 4 groups of three. Each group of three must share a common 0V. Alternatively, unshared inputs can be used for a reduced number of inputs.</p> <p><i>DT81:</i> Up to 3 voltage based inputs can be used.</p> <p><i>Example: 2 inputs per 4 wire dataTaker universal channel (common mode voltage range applies).</i></p> 	<p>Refer to the user manual for detailed connection information</p> <p><i>Example: 1 input per 4 wire dataTaker universal channel.</i></p> 
<p>How many thermocouple inputs can I use?</p>	<p><i>DT80:</i> Up to 15 thermocouple inputs can be used.</p> <p><i>DT81:</i> Up to 3 thermocouple inputs can be used. The connections used are the same as other voltage based inputs.</p>	<p>Refer to the user manual for detailed connection information</p>
<p>How many RTD inputs can I use?</p>	<p><i>DT80:</i> Up to 5 RTD inputs can be used.</p> <p><i>DT81:</i> 1 RTD input only can be used. Connection is 1 RTD per 4 wire <i>dataTaker</i> universal channel.</p>	<p>Refer to the user manual for detailed connection information</p>

DT80 and DT81 (V6) Frequently Asked Questions

How many 4-20mA inputs can I use?

Example: 4-20mA connection using internal shunt resistor.

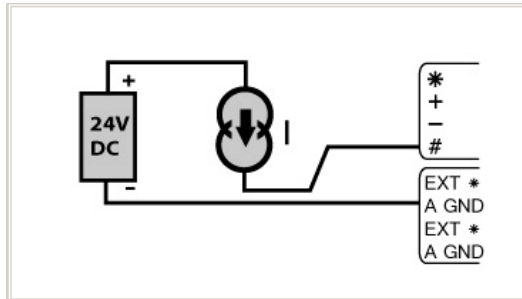

DT80: Up to 15 current loop or 4-20mA inputs can be used. A maximum of 5 inputs using the internal current shunt, or 15 using external current shunts.

DT81: Up to 3 current loop or 4-20mA inputs can be used. A maximum of 1 input using the internal current shunt, or 3 using external current shunts.

Example: 4-20mA connection using external shunt resistor.

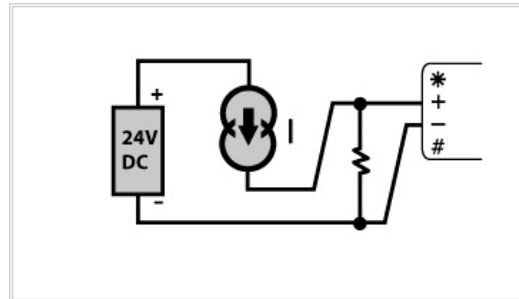

See question on 2 wire transducers. Refer to the user manual for detailed connection information.

Example: 3 x 4-20mA connection using external shunt resistor.

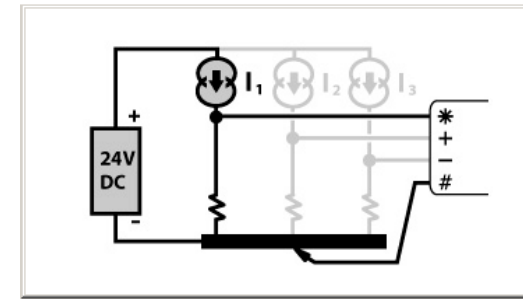

DT80 and DT81 (V6) Frequently Asked Questions

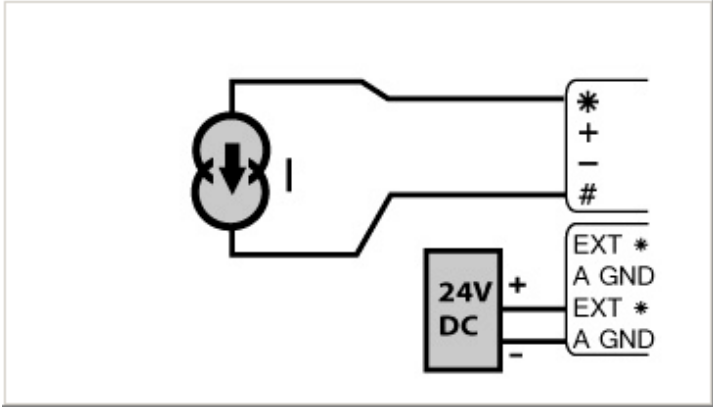
<p>Can I use 2 wire 4-20mA transducer inputs?</p>	<p>Yes, the <i>DT80/81</i> includes support for current loop inputs using the internal current shunt and an external power supply. Example: 2 wire 4-20mA connection using switched external excitation.</p> 	<p>Refer to the user manual for detailed connection information. Switched external excitation is only provided during measurement, use MD channel option to allow transducer warm up time. Not suitable for current loops that must be continuously powered or require a complete loop at all times.</p>
<p>What is meant by 'switchable current shunt'?</p>	<p>The internal current shunt is not permanently in circuit. It is only connected during an actual current measurement. For this reason it should not be used if the external circuit requires a complete loop at all times.</p>	<p>Switching the shunt out of circuit is part of the design for interchannel isolation.</p>
<p>What is meant by 'interchannel isolation'?</p>	<p>Because we have used relay multiplexors rather than solid state versions, there is complete isolation between each dataTaker 4 wire input channel. <i>DT80</i> example: sensors connected to channel 1 are isolated from sensors connected to channel 2.</p>	<p>Note that external wiring practices can affect the practical level of isolation obtained. e.g. Shared wire connections with connection of AGND to an external reference.</p>

DT80 and DT81 (V6) Frequently Asked Questions

<p>Are the analog inputs isolated?</p>	<p>Yes, the analog inputs are isolated. Relays provide interchannel isolation (for example between channels 1 & 2) and the analog system is isolated from the Communications/Digital/Power section. Because the analog section is isolated from the rest of the <i>DT80/81</i>, sensor-to-equipment ground current loops are unlikely to occur.</p>	<p>Refer to the user manual for information on the use of the AGND terminal and effects on isolation.</p>
<p>What is the input voltage range?</p>	<p>Overall range is $\pm 30\text{Vdc}$, however the default range for most measurement types is $\pm 3\text{Vdc}$. The higher $\pm 30\text{Vdc}$ range is only available if the internal attenuation is on. By default all channel types except HV and L (current loop) channel types have attenuation off.</p>	<p>See question on attenuation for additional information. Protection is provided to 50V.</p>
<p>How does the auto ranging work?</p>	<p>The <i>DT80/81</i> analog inputs can operate with 3 different levels of amplifier gain. By default the most appropriate amplifier gain is selected automatically. This allows small signals to be amplified for measurement, improving the effective resolution of that measurement. The auto ranging operates over 3 ranges that are dependant on the attenuation mode; Attenuation off: 30mV – 300mV – 3V Attenuation on: 300mV – 3V – 30V</p>	<p>See question on attenuation for additional information. Autoranging can be disabled by using Gain Lock channel options.</p>
<p>Do I still need external attenuators?</p>	<p>If your voltage input is over 30V then you will need external attenuation.</p>	

DT80 and DT81 (V6) Frequently Asked Questions

<p>What are the internal attenuators?</p>	<p>The <i>DT80/81</i> includes internal 10:1 voltage attenuators. These are switched in or out of circuit as appropriate for the channel type, or by channel option. Available voltage input ranges are; Attenuation off: 30mV – 300mV – 3V Attenuation on: 300mV – 3V – 30V By default all channel types except HV and L (current loop) channel types have attenuation off.</p>	
<p>Can I use a common power supply for the <i>DT80/81</i> and Switched External Excitation?</p>	<p>Yes, as long as the rating is sufficient to cater for both logger and sensor requirements. Note that only 1 sensor will be excited at any one time through this method.</p>	<p>Use of a common power supply may impact on isolation of the Analog sub section. Care must be taken to avoid ground loops or unintended current loops.</p>
<p>How do I allow for sensor warm up before measurement?</p>	<p>If using the Switched External Excitation, by setting the MD channel option to the delay required for each individual sensor input. This is very useful with 2 wire 4-20mA transducers using Switched External Excitation. If using external power switched via the Latching Relay, this will depend on your program but may require a DELAY channel or PAUSE command within the schedule in place of the MD channel option.</p>	
<p>Where has the P10 setting for ADC settling time gone in the programming code?</p>	<p>There is no global parameter setting for ADC settling time in the <i>DT80</i>. This has been replaced by the MD channel option, allowing different settings for each channel.</p>	<p>Default measurement delay (settling time) is 10mS.</p>

DT80 and DT81 (V6) Frequently Asked Questions

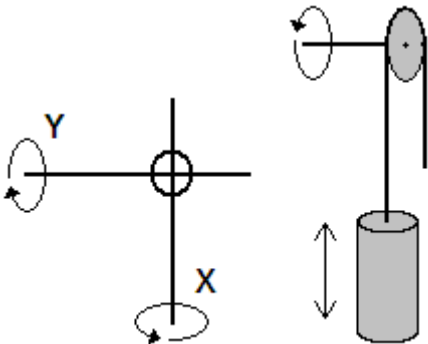
<p>What is the setting range for the MD channel option?</p>	<p>Measurement Delay of 0-30,000mS can be set using the MD channel option.</p>	
<p>What is the rating of the Switched External Excitation circuit?</p>	<p>Nominally 30VDC, 50mA.</p>	
<p>Digital Channels</p>		
<p>Question</p>	<p>Answer</p>	<p>Notes</p>
<p>What can I use the Phase Encoder inputs for?</p>	<p>Phase encoders can be used for accurate measurement of shaft rotation, direction, speed and position. For example the position of a rotating assembly could be monitored in degrees or the position of a roller door monitored via the motor shaft rotation. This allows very accurate monitoring of position from drive components rather than direct measurement of the driven part.</p>	<p><i>DT80</i> will support 2 phase encoders allowing XY position logging. <i>DT81</i> will support 1 phase encoder only, so can only monitor a single axis.</p> 

DT80 and DT81 (V6) Frequently Asked Questions

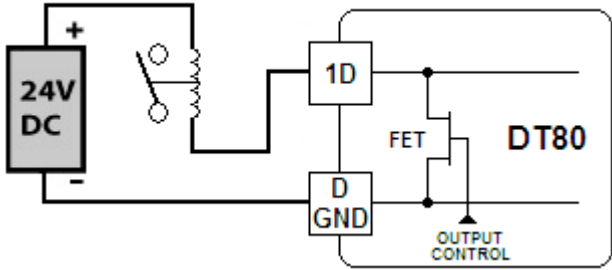
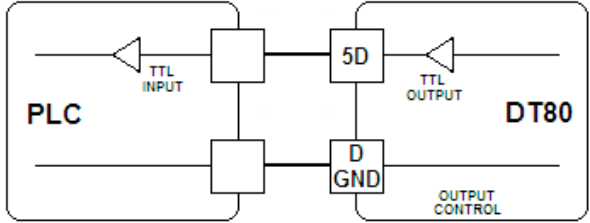
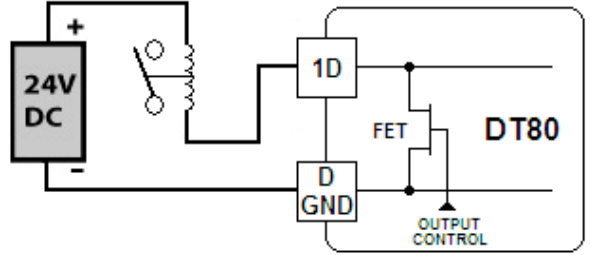
<p>What does 'Open Collector' and 'Active Drive' mean?</p>	<p>Two different digital output types are used on the DT80/81. The Open Collector or Open Drain type is suitable for connection of relays etc and requires an external power supply. The Active Drive type is a TTL logic level output that requires no external power supply. Active drive can be used for input to other devices such as PLCs.</p> <p><i>Example: Open Collector connecting relays.</i></p> 	<p><i>Example: Active Drive connecting PLC.</i></p> 
<p>How do I connect additional relays to the DT80/81?</p>	<p>Use digital outputs 1D-4D (DT80) or 1D-3D (DT81) with an external power supply.</p>	

DT80 and DT81 (V6) Frequently Asked Questions

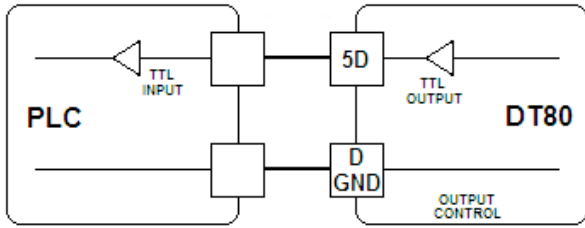
<p>How do I connect the digital outputs to TTL input devices like a PLC?</p>	<p>The easiest method is to use 5D-8D (<i>DT80</i>) as they are Active Drive, compatible with TTL devices. The <i>DT81</i> has a single Active Drive output, this being 4D.</p>	
<p>Does the Relay output change state when the logger goes to sleep?</p>	<p>When the logger is operating normally (including low power mode) the operation is latching. Once set ON it will maintain that condition until it has been set OFF.</p>	<p>If the logger loses all power then the relay state is unknown.</p>
<p>Serial Sensor Channel (<i>DT80</i>)</p>		
<p>Question.</p>	<p>Answer.</p>	<p>Notes.</p>
<p>Does it support SDI-12?</p>	<p>No, this port can be configured for RS-232, RS-422 or RS-485 comms standards. SDI-12 support is provided by the digital I/O channels.</p>	<p><i>DT80</i>: 5D-8D are SDI-12 compatible. <i>DT81</i>: 4D is SDI-12 compatible. See section on SDI-12 and user manual.</p>
<p>Does it support Modbus?</p>	<p>Yes, the <i>DT80</i> (from V6) includes support for Modbus on all serial ports. The <i>DT80/81</i> is a Modbus 'server' or 'slave' and will respond to requests from a Modbus 'client' or 'master'. If using the RS422/485 the Serial port address can be modified by the MODBUS_SERVER profile settings..</p>	<p>Note that once configured as a Modbus port the Serial Sensor Channel is not available other use.</p>

DT80 and DT81 (V6) Frequently Asked Questions

How do I program this channel?	String commands and data parsing are programmed using either the <i>DeLogger 4</i> expression builder or in native text code.	Requires knowledge of the data formats and dataTaker command language. Refer to the <i>DT80</i> User Manual for additional information.
SDI-12		
Question	Answer	Notes
Which versions of SDI-12 are supported?	Versions 1.0, 1.2 and 1.3 are supported by the <i>DT80/81</i> . Generally the <i>DT80/81</i> can determine which version of the standard a given sensor supports automatically.	Refer to the user manual for detailed SDI-12 information.
Is Continuous Measurement mode supported?	Yes, the <i>DT80/81</i> supports both Measure on Demand and Continuous Measurement modes.	Mode must be supported by the sensor to be accessed.
How do I program a SDI-12 channel?	Like any other <i>dataTaker</i> channel type the measurement is defined using a set of instructions and channel options. Example: 7SDI12(AD3,R104,"Pressure~hPa") Reads specific data from sensor address 3 and applies a channel name and engineering units.	Currently SDI-12 channel support is only provided in text programming form. This can be accessed within DeLogger via the User Channel type. Sensor data sheets should be examined to determine how SDI-12 is supported by that particular sensor.
How many SDI-12 sensors can I connect?	Up to ten (10) SDI-12 sensors can be connected to each <i>DT80/81</i> SDI-12 capable input terminal. <i>DT80</i> : Maximum 40 SDI-12 sensors. <i>DT81</i> : Maximum 10 SDI-12 sensors.	

DT80 and DT81 (V6) Frequently Asked Questions

Use of Memory		
Question	Answer	Notes
What is meant by pre allocated files?	The <i>DT80/81</i> uses a fixed file size for logging data from each schedule. The size of this file is set as part of the data logger program. As such the size is allocated before data logging begins.	Default size is 1MB per schedule. File size can be set in units of time, records or bytes for time based schedules. Schedules with event based triggers use records or bytes.
Where has the /O overwrite mode switch gone in the programming code?	Overwrite mode is now controlled on a per schedule basis, with separate control for data and alarms within a schedule.	Default mode is overwrite on for all schedules.
I need to capture infrequent events over longer time periods, but don't want to log all the information between events?	Logged data files can be archived using the new ARCHIVE command. This allows multiple optimally sized files, each containing just the event data you want.	Used in conjunction with Alarms. Refer to the user manual for detailed command information.
I seem to have less data logged than I should have?	The size of the data store file may be set too small for the application. Set the file size for that schedule via the Trigger Rate – Options menu.	Default size is 1MB per schedule. File size can be set in units of time, records or bytes for time based schedules. Schedules with event based triggers use records or bytes.

DT80 and DT81 (V6) Frequently Asked Questions

Downloading Data		
Question	Answer	Notes
Can I choose how much memory to download?	Yes, it is possible to download individual schedules only, or time to time periods of all or any individual schedule. In addition time to end, or beginning to time.	
Can I download while the logger is logging?	Yes, downloading or transfer of data from the <i>DT80/81</i> via a host port, FTP or USB flash drive doesn't stop data logging, but may limit the speed of faster schedules (1 second or faster) and will effect return of data to a PC in real time.	
Can I download by time?	Yes, time to time, or start of file to time, or time to end of file. All schedules or by individual schedule.	
How long does it take to download a 1MB data file?	Using default settings and a 1MB data store file, standard UNLOAD time is; USB: approximately 3 minutes. RS232: approximately 5 minutes (@57600 baud). ETHERNET: approximately 3 Minutes. Transfer of binary files using FTP is much faster than standard unload.	The standard UNLOAD command unloads ASCII data (in a CSV format). Replay files are also CSV files but include additional information.
What is the fastest way to unload my data logger?	Using FTP (File Transfer Protocol) over Ethernet. A 1 MB data store file will be transferred in less than 10 seconds.	Assuming typical LAN performance. Transferred file is in binary format and requires a utility such as DeView to view or export the data.

DT80 and DT81 (V6) Frequently Asked Questions

<p>Can I use a PDA to download data?</p>	<p>Yes, use either the web browser interface or <i>DeMobile8</i> software (PDAs running the PocketPC2003 OS).</p>	<p>Network connection required for web browser interface, this would typically be WiFi. BlueTooth or RS232 interface is required for <i>DeMobile</i> (PDA) to <i>DT80</i> communications.</p>
<p>Can I download data using a USB Flash Disk?</p>	<p>Yes, the COPYDATA or MOVEDATA commands can be used to either copy or move the binary data files from the internal disk to the USB memory stick.</p>	<p>A utility such as <i>DeView</i> is required to view or export the data from the binary file.</p>
<p>How fast is downloading to the USB flash disk?</p>	<p>This will vary due to performance variations with the USB flash disks, as well as be affected by the size of the files and how much data is actually stored. For a 1MB file the approximate transfer time will be 20-30 seconds. Actual transfer time will also be effected by other logger activity.</p>	<p>Using COPYDATA command to create a binary file on the USB flash disk. Does not include time to read and recognise the flash disk on insert.</p>
<p>Can I get my data over the internet?</p>	<p>Yes, Either using direct connections within <i>DeLogger</i>, <i>DeLoad</i> or <i>DeTransfer</i> or with FTP using a browser or FTP client the binary data store files can be copied from the <i>DT80</i>.</p>	<p>Internet access requires the <i>DT80</i> to assigned a visible IP address. You may need to place it outside a firewall to be visible. A utility such as <i>DeView</i> is required to view or export the data from the binary file.</p>

DT80 and DT81 (V6) Frequently Asked Questions

Can I FTP data files?	Yes, data store files can be moved using FTP via Ethernet or RS232/PPP.	Can see FTP folders from IE and other browsers. Must be remote request from FTP Client. Supports anonymous login – read only.
Can I read my data using Notepad or Excel?	Standard UNLOAD and REPLAY files are text files using a CSV format, these can be viewed using text editors or spreadsheets. Binary data store files need a utility like DeView to view or export the data to a CSV format.	Normal unload generates CSV text based files in either .csv or .dlr (REPLAY) file types. Binary files are those found on the USB flash disk or transferred using FTP.
Real Time Clock		
Question	Answer	Notes
What is the accuracy of the DT80/81 clock?	Typically 5 secs/month over 0-40C. 20 secs/month over full temp range	
Firmware		
Question	Answer	Notes
Is the firmware upgradeable?	Yes, via USB, RS232 or USB flash disk.	
Is the firmware from the DT800?	No, the DT80/81 and DT800 use a common source code base (V5 and up) but the firmware is not interchangeable.	
How can I get new firmware?	New firmware is available from the Datataker website www.datataker.com or from a current resource CD.	

DT80 and DT81 (V6) Frequently Asked Questions

Programming & Commands		
Question	Answer	Notes
Do I have to learn the programming text language?	No, most straightforward data logging tasks can be programmed using the <i>DeLogger 4</i> program builder functions.	
Can I modify a program that is already in the <i>DT80/81</i>?	No, a new program must be loaded. The program can be read from the data logger in text form using the SHOWPROG command. It can then be modified before being loaded back to the <i>DT80/81</i> . This is only possible in text form, <i>DeLogger 4</i> cannot reconstruct the program builder format from a text file.	Program constants held in CVs (channel variables) can be modified at any time. Schedule rates can be changed at any time. Any channel can be read at any time without reprogramming by sending the appropriate text commands to the data logger.
What debugging tools are available?	The <i>DT80/81</i> has debugging support and error reporting capability. This includes reporting the position of an error in a program either as a text return or in the Error pane in <i>DeLogger 4</i> . In addition two log files are available; UERRLOG returns errors (exceptions/assertions). UEVTLOG returns contents of event log.	Example; <i>dataTaker 80 E3 - Channel option error at line 3 col 5 [1TK(<err>THERMOCOUP]</i> <err> marks position of error, in this case quotation marks are missing. E3 – Channel option error - Illegal channel option used - Incompatible options used - Option invalid for channel type

DT80 and DT81 (V6) Frequently Asked Questions

How do I comment my text program files?	Comments can be inserted by use of a apostrophe character (') followed by text comments, up to a carriage return. Example: <i>' This line returns air temperature 1TK("Ambient")</i>	Commenting by use of lower case characters only is no longer valid, as the <i>DT80/81</i> is not case sensitive for commands.
Are commands case sensitive?	No, commands are accepted in upper, lower or mixed case.	Switch settings are case sensitive.
How can I learn more about programming?	The Datataker website contains training resources including worked examples for programming many typical tasks. www.datataker.com.au	Datataker also conducts training workshops suitable for beginners or experienced users.
Alarms		
Question	Answer	Notes
Are Alarms logged to memory?	Yes, if Alarms are numbered they are logged to the data store file for the schedule they are tested in.	The space allocated for Alarm storage and Overwrite mode are selected via Schedule options (advanced tab in <i>DeLogger 4</i>).
What can be tested in Alarms?	All input and internal channel types can be tested in Alarms including analog and digital inputs as well as time, channel and system variables.	Refer to the Users Manual for detailed information on Alarms.

DT80 and DT81 (V6) Frequently Asked Questions

Can an Alarm be added to a channel being logged?	No, Alarms are treated as separate channels by the data logger. If a channel needs to be logged as data and also be tested in an Alarm, two channels must be used.	Refer to the Users Manual for detailed information on Alarms.
How do I display Alarms?	Only numbered Alarms are displayed, if numbered they are also logged to memory.	For Alarms that must be logged but not displayed, use the ND (no display) channel option.